

REMOVAL

1. DISCONNECT CABLE FROM NEGATIVE BATTERY TERMINAL
2. REMOVE FRONT WHEEL
3. REMOVE NO.1 ENGINE UNDER COVER SUB-ASSEMBLY
4. REMOVE REAR ENGINE UNDER COVER ASSEMBLY
5. DRAIN DIFFERENTIAL OIL
6. REMOVE FRONT PROPELLER SHAFT ASSEMBLY
(See page [PR-2](#))
7. SEPARATE SPEED SENSOR FRONT LH (See page [DS-3](#))
8. SEPARATE FRONT SPEED SENSOR RH
HINT:
Use the same procedure as for the RH side.
9. REMOVE FRONT AXLE HUB GREASE CAP LH (See page [DS-3](#))
10. REMOVE FRONT AXLE HUB GREASE CAP RH
HINT:
Use the same procedure as for the RH side.
11. SEPARATE TIE ROD END SUB-ASSEMBLY LH (See page [DS-3](#))
12. SEPARATE TIE ROD END SUB-ASSEMBLY RH
13. SEPARATE FRONT LOWER BALL JOINT ATTACHMENT (See page [DS-4](#))
14. REMOVE FRONT AXLE HUB NUT LH (See page [DS-3](#))
15. REMOVE FRONT AXLE HUB NUT RH
HINT:
Use the same procedure as for the RH side.
16. REMOVE FRONT DRIVE SHAFT ASSEMBLY LH (See page [DS-4](#))
17. REMOVE FRONT DRIVE SHAFT ASSEMBLY RH
HINT:
Use the same procedure as for the RH side.
18. REMOVE FRONT DIFFERENTIAL CARRIER ASSEMBLY
 - (a) Remove the bolt and disconnect the differential breather tube bracket.
 - (b) Support the differential with a jack.
 - (c) Remove the No. 1 differential mounting nut.
 - (d) Remove the 2 mounting bolts and 2 nuts.
 - (e) Lower the jack and remove the front differential.

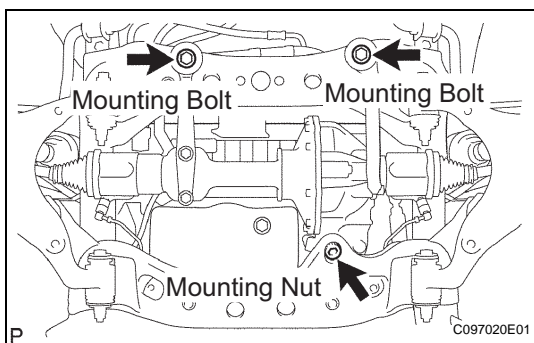

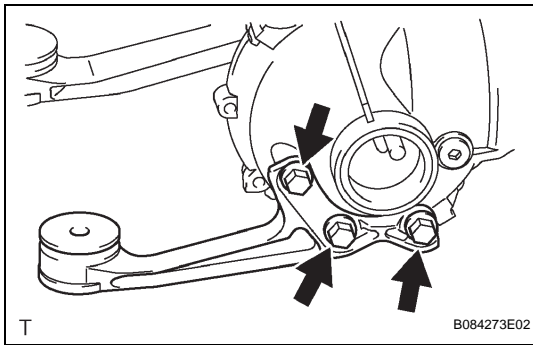

- (f) Remove the 3 bolts and front No. 1 differential support.

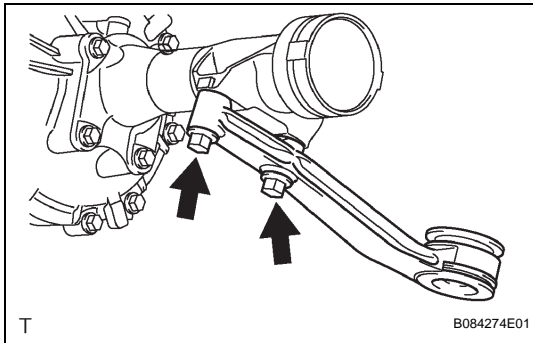

- (g) Remove the 2 bolts and front No. 2 differential support.

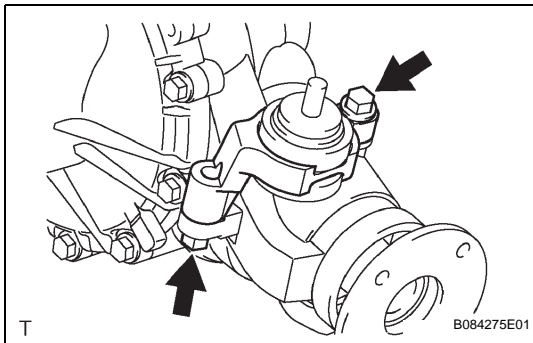

- (h) Remove the 2 bolts and front No. 3 differential support.

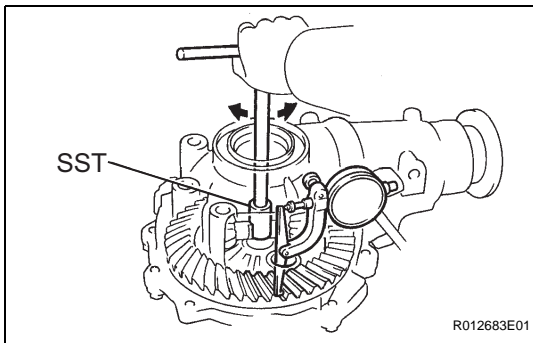

DISASSEMBLY

1. INSPECT DIFFERENTIAL RING GEAR BACKLASH

- (a) Using SST and a dial indicator, measure the ring gear backlash.

SST 09564-32011

Standard:

0.11 to 0.21 mm (0.0043 to 0.0083 in.)

If the backlash is not as specified, adjust the side bearing preload or repair as necessary.

HINT:

Perform the measurements at 3 or more positions around the side bearing preload.

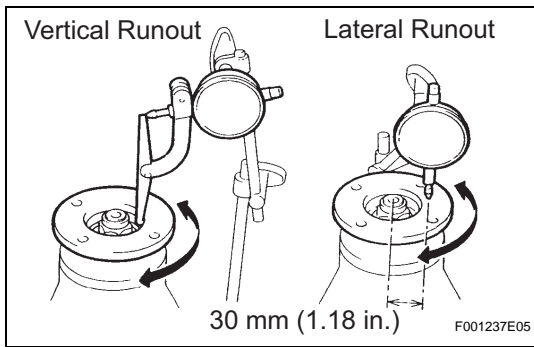

2. INSPECT FRONT DRIVE PINION COMPANION FLANGE SUB-ASSEMBLY

- (a) Using a dial indicator, measure the runout of the companion flange vertically and laterally.

Maximum runout

Runout	Maximum
Vertical runout	0.10 mm (0.0039 in.)
Lateral runout	0.10 mm (0.0039 in.)

If the runout is greater than the maximum, replace the companion flange.

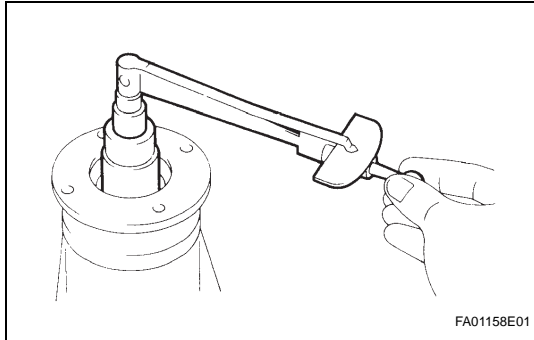

3. INSPECT DRIVE PINION PRELOAD

- (a) Using a torque wrench, measure the preload of the backlash between the drive pinion and ring gear.

HINT:

Bolts without torque specifications are shown in the service data (see page [SS-43](#)).

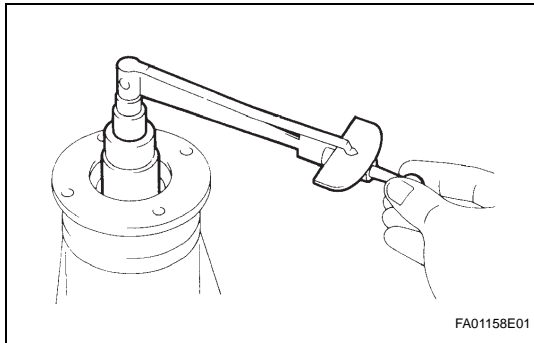

4. INSPECT TOTAL PRELOAD

- (a) Using a torque wrench, measure the preload with the teeth of the drive pinion and ring gear in contact.

HINT:

Bolts without torque specifications are shown in the service data (see page [SS-43](#)).

If necessary, disassemble and inspect the differential.



5. REMOVE DIFFERENTIAL VACUUM ACTUATOR ASSEMBLY

- (a) Remove the 4 bolts.
 (b) Using a hammer, pry out the actuator from the differential tube.

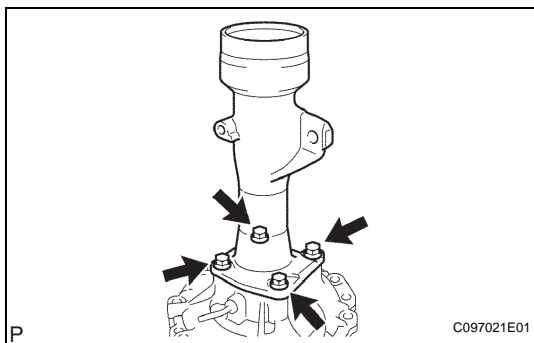

6. REMOVE FRONT DIFFERENTIAL TUBE ASSEMBLY

- (a) Remove the 4 bolts.
 (b) Using a plastic-faced hammer, tap out the differential tube.

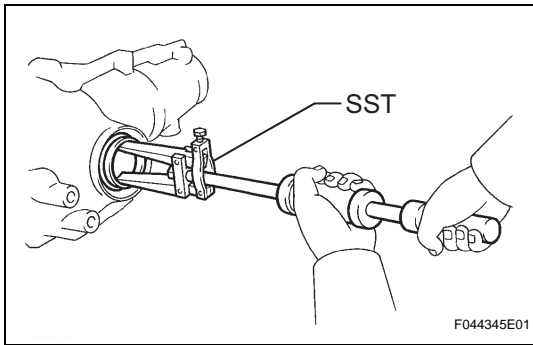

7. REMOVE DIFFERENTIAL SIDE GEAR SHAFT OIL SEAL

- (a) Using SST, tap out the oil seal.
SST 09308-00010

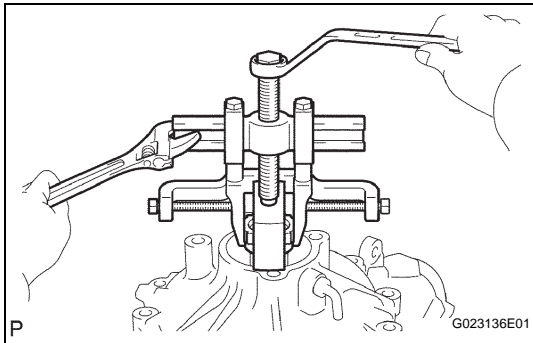

8. REMOVE DIFFERENTIAL SIDE GEAR INTER SHAFT SUB-ASSEMBLY

- (a) Using SST, remove the inter shaft.
SST 09350-20015 (09369-20040), 09950-40011 (09951-04010, 09952-04010, 09953-04020, 09954-04010, 09955-04011, 09957-04010, 09958-04011)
- (b) Remove the snap ring from the inter shaft.

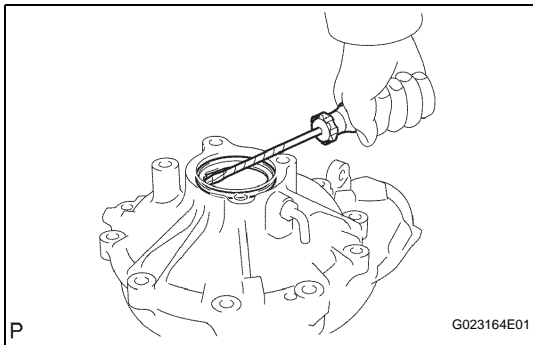

9. REMOVE FRONT DIFFERENTIAL SIDE BEARING RETAINER DEFLECTOR

- (a) Using a screwdriver with its tip wrapped in protective tape, pry out the bearing retainer deflector.

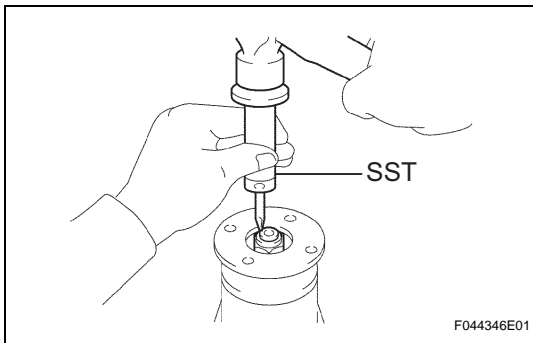

10. REMOVE FRONT DRIVE PINION COMPANION FLANGE NUT

- (a) Using SST and a hammer, loosen the staked part of the nut.

SST 09930-00010

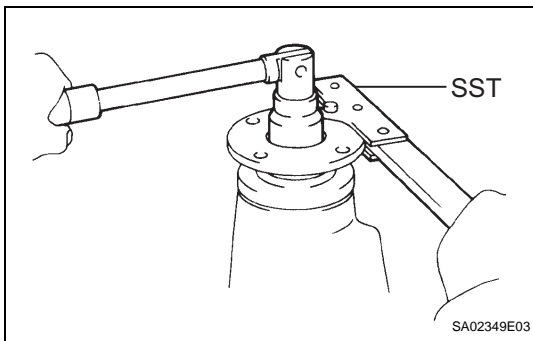

- (b) Using SST to hold the companion flange in place, remove the nut.

SST 09330-00021

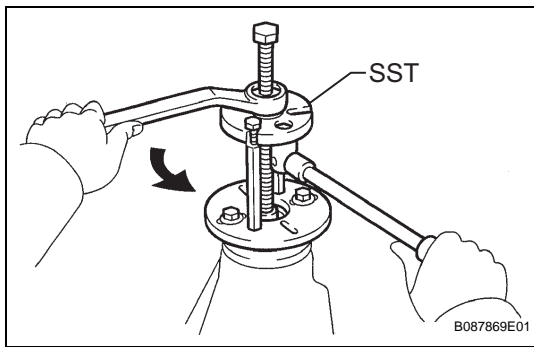

11. REMOVE FRONT DRIVE PINION COMPANION FLANGE SUB-ASSEMBLY

- (a) Using SST, remove the companion flange.
SST 09950-30012 (09951-03010, 09953-03010, 09954-03010, 09955-03030, 09956-03020)

NOTICE:

Before using SST (center bolt), apply hypoid gear oil to its threads and tip.

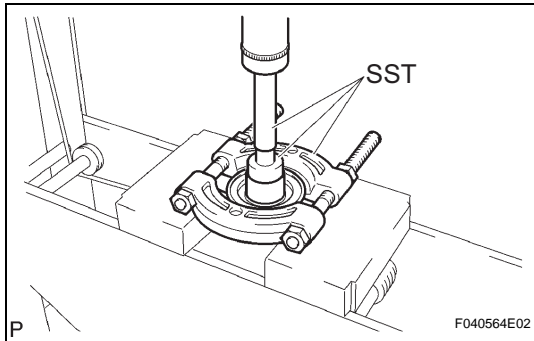

12. REMOVE FRONT DIFFERENTIAL DUST DEFLECTOR

- (a) Using SST and a press, press out the dust deflector.
SST 09950-00020, 09950-60010 (09951-00510), 09950-70010 (09951-07150)

NOTICE:

Do not drop the companion flange.

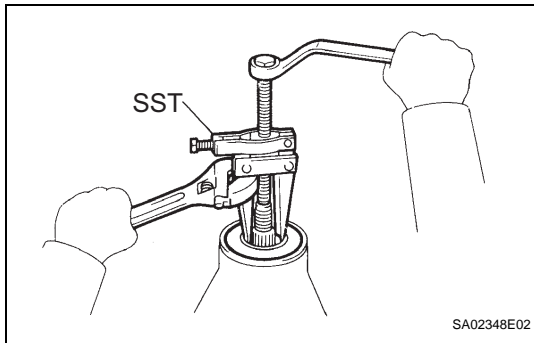

13. REMOVE REAR DIFFERENTIAL CARRIER OIL SEAL

- (a) Using SST, remove the oil seal from the differential carrier.
SST 09308-10010

14. REMOVE FRONT DIFFERENTIAL DRIVE PINION OIL SLINGER

- (a) Remove the oil slinger from the drive pinion.

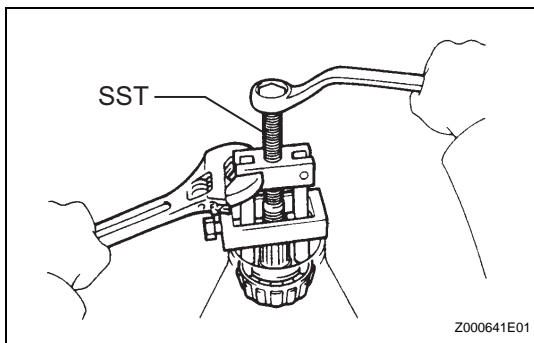

15. REMOVE FRONT DRIVE PINION REAR TAPERED ROLLER BEARING

- (a) Using SST, remove the roller bearing (inner) from the drive pinion.
SST 09556-22010
 (b) Remove the bearing spacer.

16. REMOVE DIFFERENTIAL SIDE BEARING RETAINER

- (a) Remove the 10 bolts and tap out the retainer with a plastic-faced hammer.

17. REMOVE DIFFERENTIAL CASE ASSEMBLY

18. REMOVE DIFFERENTIAL DRIVE PINION

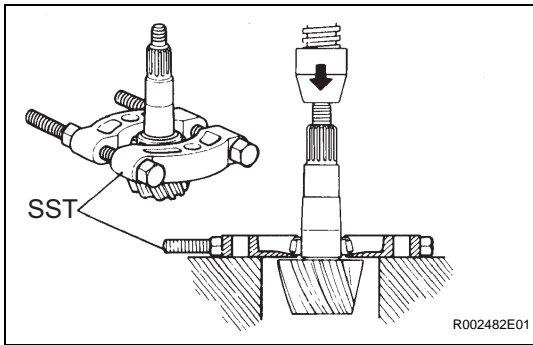

19. REMOVE FRONT DRIVE PINION FRONT TAPERED ROLLER BEARING

- (a) Using SST and a press, press out the roller bearing (inner) from the drive pinion.

SST 09950-00020

NOTICE:

Do not drop the drive pinion.

HINT:

If the drive pinion or ring gear is damaged, replace them as a set.

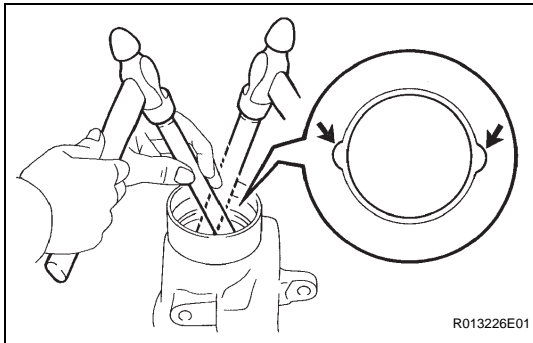

20. REMOVE FRONT DRIVE PINION FRONT TAPERED ROLLER BEARING

- (a) Using a brass bar and hammer, tap out the roller bearing (outer).

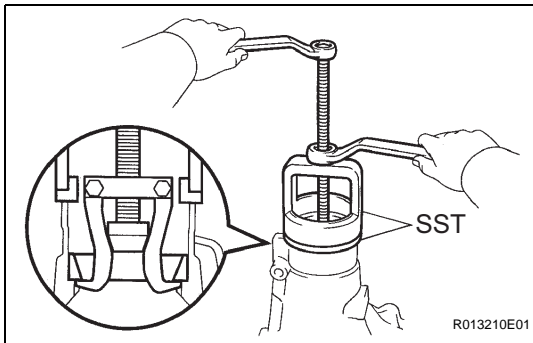

21. REMOVE FRONT DRIVE PINION REAR TAPERED ROLLER BEARING

- (a) Using SST, remove the roller bearing (outer).

SST 09502-12010, 09612-65014 (09612-01020, 09612-01050)

22. REMOVE FRONT DIFFERENTIAL OIL STORAGE RING

- (a) Using a brass bar and hammer, tap out the oil storage ring.

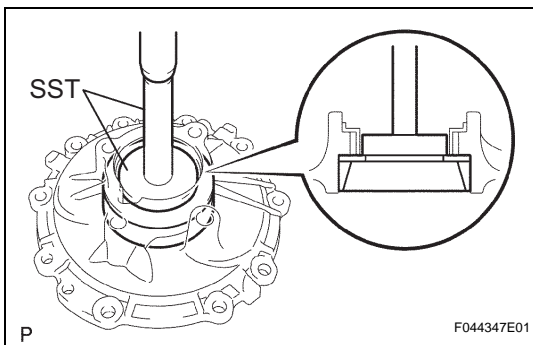

23. REMOVE FRONT DIFFERENTIAL CASE BEARING

HINT:

- Measure the thickness of the case washer.
- Tag the bearing outer races to show the location for reassembly.

- (a) Using SST and a press, press out the case bearing (outer race) and plate washer from the bearing retainer.

SST 09950-60020 (09951-00680), 09950-70010 (09951-07150)

If the bearing is damaged during removal, replace it.

- (b) Using SST and a press, press out the case bearing (outer race) and plate washer from the differential carrier.

SST 09950-60020 (09951-00680), 09950-70010 (09951-07150)

If the bearing is damaged during removal, replace it.

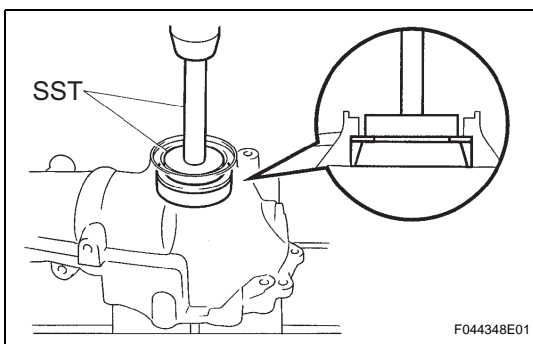

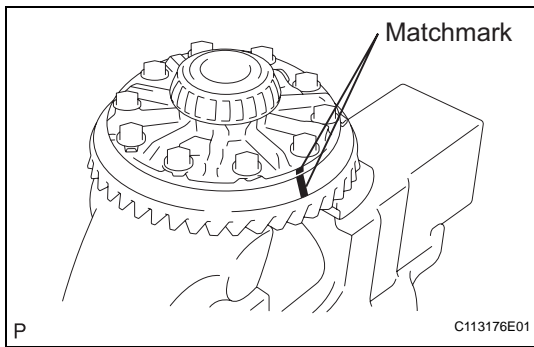

24. REMOVE DIFFERENTIAL RING GEAR

- (a) Place matchmarks on the ring gear and differential case.
- (b) Remove the 10 ring gear set bolts.

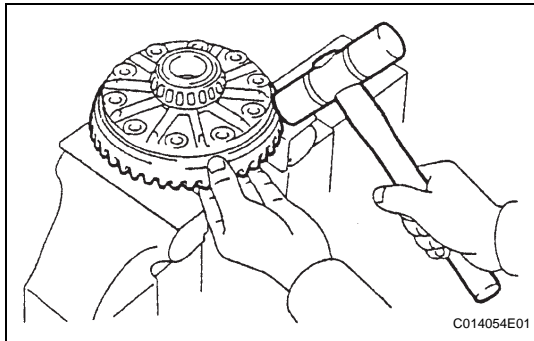

- (c) Using a plastic-faced hammer, tap on the ring gear to separate it from the differential case.

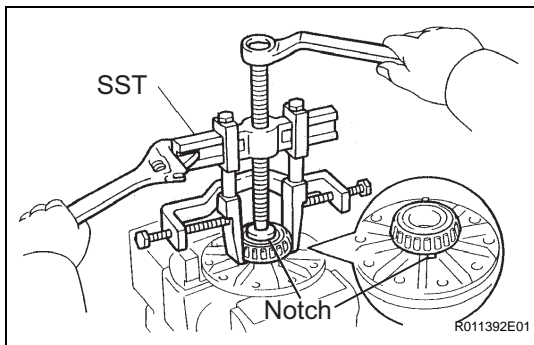

25. REMOVE FRONT DIFFERENTIAL CASE BEARING

HINT:

The differential case and case bearings should only be removed when replacement is necessary.

- (a) Using SST, remove the 2 case bearings (inner) from the differential case.

SST 09950-60010 (09951-00480), 09950-40011 (09951-04020, 09952-04010, 09953-04030, 09954-04010, 09955-04061, 09953-04020, 09958-04011)

HINT:

Fix the claws of SST to the notch in the differential case assembly.

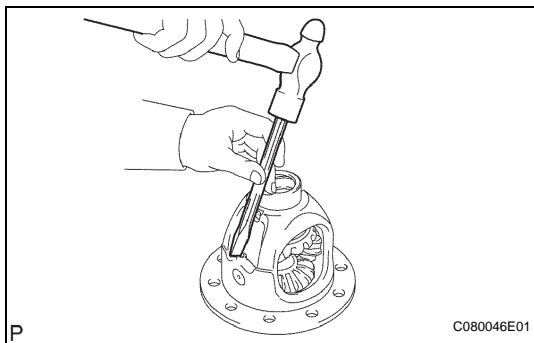

26. DISASSEMBLE DIFFERENTIAL CASE

- (a) Using a chisel and hammer, unstick the differential case.

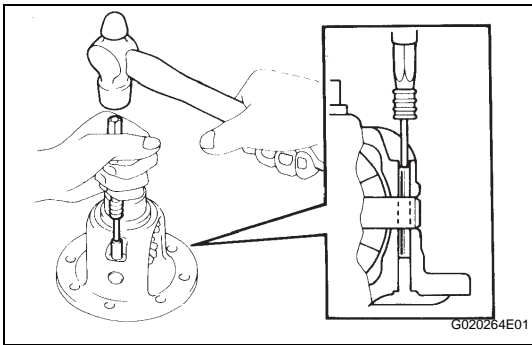

- (b) Using a pin punch and hammer, tap out the straight pin.

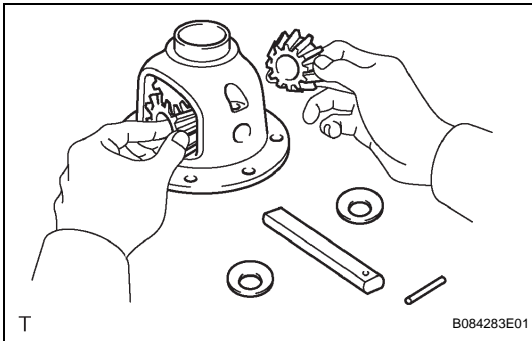

- (c) Remove the following parts from the differential case.

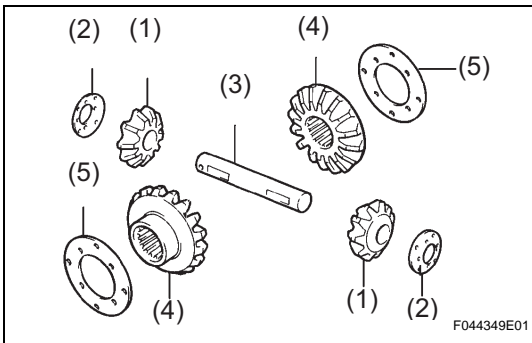

- (1) Differential pinion gear (2 pieces)
- (2) Differential pinion gear thrust washer (2 pieces)
- (3) Differential pinion shaft
- (4) Differential side gear (2 pieces)
- (5) Differential side gear thrust washer (2 pieces)

27. INSPECT DIFFERENTIAL GEAR KIT

- (a) Check that the differential pinion and differential side gear are not damaged.
If the differential pinion or differential side gear is damaged, replace the differential gear kit.

28. INSPECT FRONT DIFFERENTIAL CASE

- (a) Check that the differential case is not damaged.
If the differential case is damaged, replace it.

29. REMOVE FRONT DIFFERENTIAL SIDE GEAR NEEDLE ROLLER BEARING

- (a) Using a brass bar and hammer, tap out the 2 bearings.

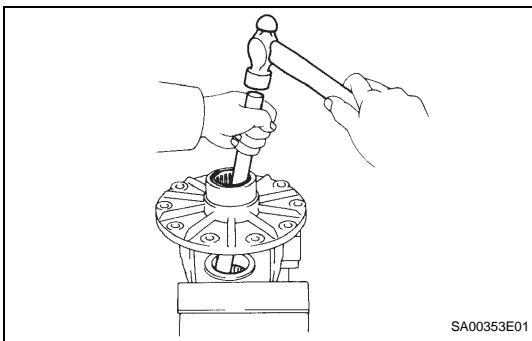

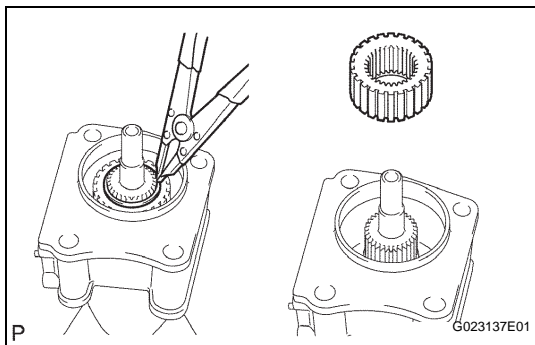
**30. REMOVE DIFFERENTIAL CLUTCH HUB**

- (a) Using a snap ring expander, remove the snap ring.
- (b) Remove the differential clutch hub.

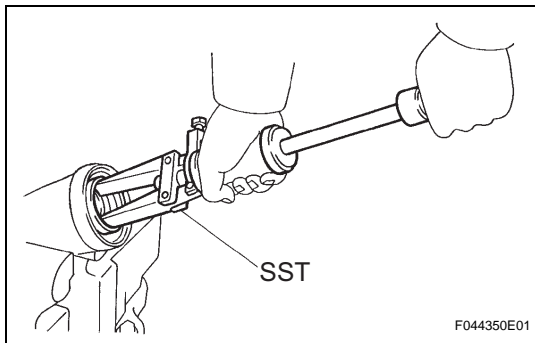
**31. REMOVE DIFFERENTIAL SIDE GEAR SHAFT OIL SEAL**

- (a) Using SST, tap out the oil seal from the differential tube.

SST 09308-00010

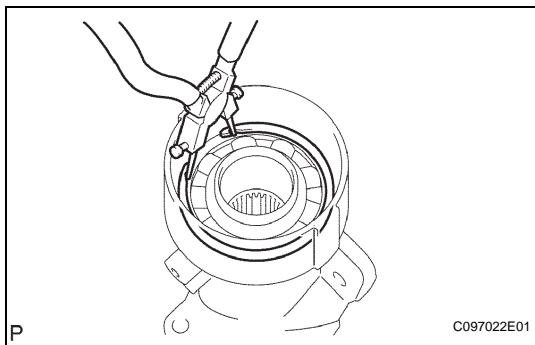
**32. REMOVE DIFFERENTIAL SIDE GEAR SHAFT SUB-ASSEMBLY RH**

- (a) Using a snap ring expander, remove the snap ring.
- (b) Remove the shaft from the differential tube.

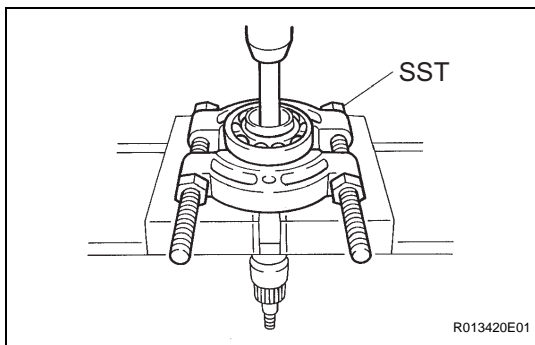
**33. REMOVE FRONT DIFFERENTIAL SIDE GEAR SHAFT RH BEARING**

- (a) Using a snap ring expander, remove the snap ring.
- (b) Using SST, a brass bar and a press, press out the shaft RH bearing.

SST 09950-00020

NOTICE:

- Do not damage the bearing.
- Do not drop the shaft.

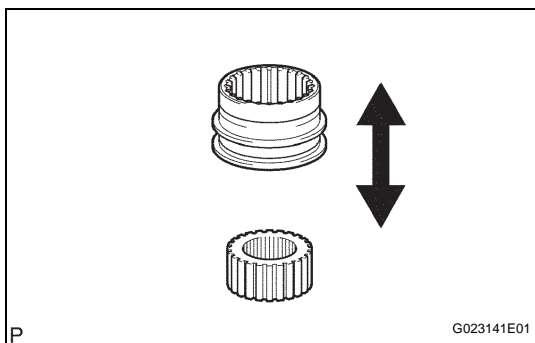
**34. INSPECT DIFFERENTIAL CLUTCH SLEEVE AND DIFFERENTIAL CLUTCH HUB**

- (a) Check that there is no wear or damage on the clutch hub and clutch sleeve. Replace parts as necessary.
- (b) Check that the clutch sleeve slides smoothly on the clutch hub. Replace parts as necessary.

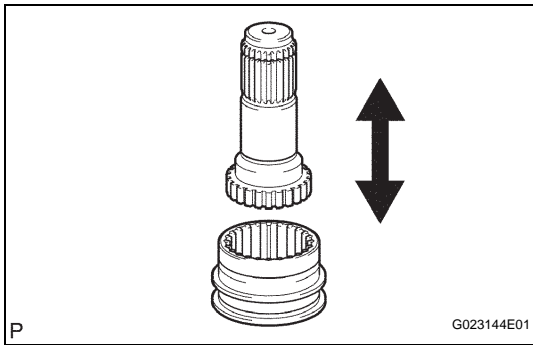

35. INSPECT DIFFERENTIAL CLUTCH SLEEVE AND DIFFERENTIAL SIDE GEAR INTER SHAFT

- (a) Check that there is no wear or damage on the clutch sleeve and side gear inter shaft.
Replace parts as necessary.
- (b) Check that the clutch sleeve slides smoothly on the side gear inter shaft.
Replace parts as necessary.

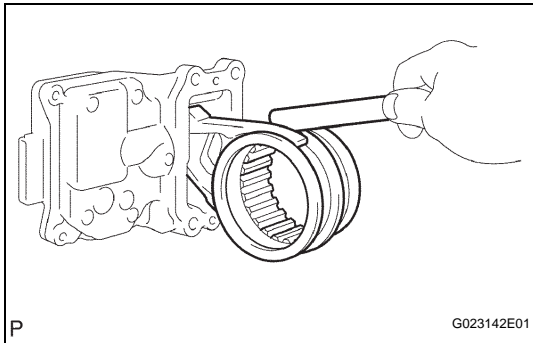

36. INSPECT DIFFERENTIAL CLUTCH SLEEVE AND CLUTCH SLEEVE FORK CLEARANCE

- (a) Using a feeler gauge, measure the clearance between the sleeve fork and clutch sleeve.

Maximum clearance:

0.15 to 0.35 mm (0.0059 to 0.0138 in.)

If the clearance is greater than the maximum, replace the fork or clutch sleeve.

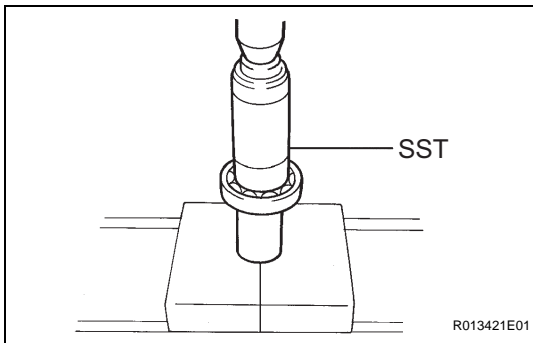

REASSEMBLY

1. INSTALL FRONT DIFFERENTIAL SIDE GEAR SHAFT RH BEARING

- (a) Using SST and a press, press in the shaft bearing.
SST 09223-00010
- (b) Using a snap ring expander, install the snap ring.
HINT:
Install the snap ring securely.

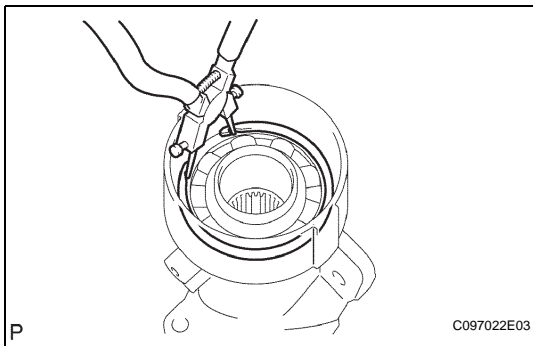

2. INSTALL DIFFERENTIAL SIDE GEAR SHAFT SUB-ASSEMBLY RH

- (a) Install the shaft into the differential tube.
- (b) Using needle nose pliers, install the snap ring.
HINT:
Install the snap ring securely.

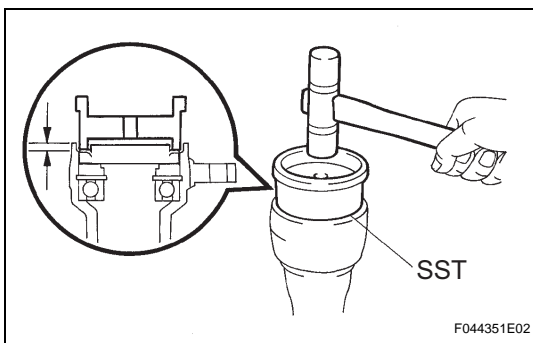

3. INSTALL DIFFERENTIAL SIDE GEAR SHAFT OIL SEAL

- (a) Coat the lip of a new oil seal with MP grease.
Oil seal depth:
4.8 to 5.8 mm (0.189 to 0.229in.)
- (b) Using SST and a plastic-faced hammer, tap in the oil seal.
SST 09223-15020

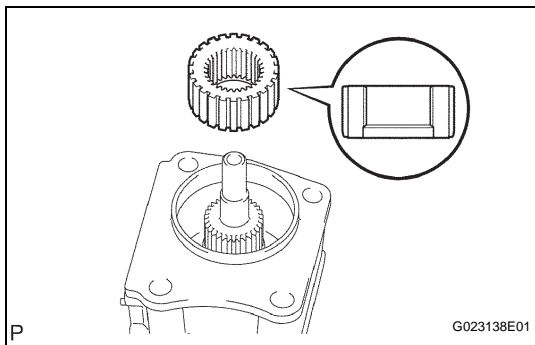

4. INSTALL DIFFERENTIAL CLUTCH HUB

- (a) Install the clutch hub onto the side gear inter shaft.
- (b) Using snap ring pliers, install the snap ring.

HINT:

Install the snap ring securely.

NOTICE:

Install the differential clutch hub in the correct direction.

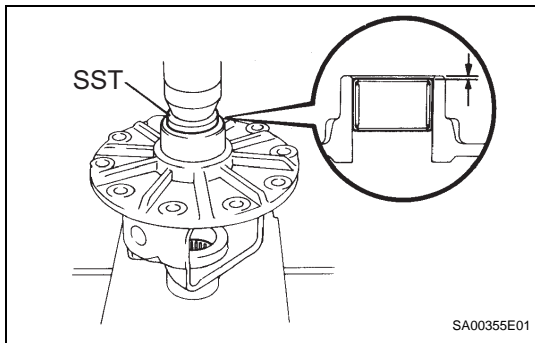

5. INSTALL FRONT DIFFERENTIAL SIDE GEAR NEEDLE ROLLER BEARING

- (a) Using SST and a press, press in 2 new bearings.

SST 09950-60010 (09951-00380)

Needle roller bearing depth:

1.4 to 2.0mm (0.055 to 0.079in.)

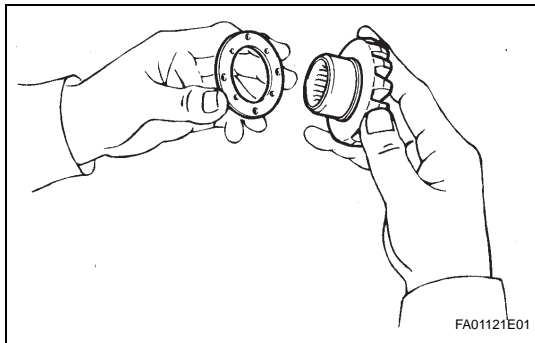

6. ASSEMBLE DIFFERENTIAL CASE

- (a) Install the 2 thrust washers onto the 2 side gears.

HINT:

Using the table below, select 2 thrust washers which will ensure that the backlash is within the specifications.

Thrust washer thickness

Thickness mm (in.)	Thickness mm (in.)
1.48 to 1.52 (0.0583 to 0.0598)	1.73 to 1.77 (0.0681 to 0.0697)
1.53 to 1.57 (0.0602 to 0.0618)	1.78 to 1.82 (0.0701 to 0.0717)
1.58 to 1.62 (0.0622 to 0.0638)	1.83 to 1.87 (0.0720 to 0.0736)
1.63 to 1.67 (0.0642 to 0.0657)	1.88 to 1.92 (0.0740 to 0.0756)
1.68 to 1.72 (0.0661 to 0.0677)	-

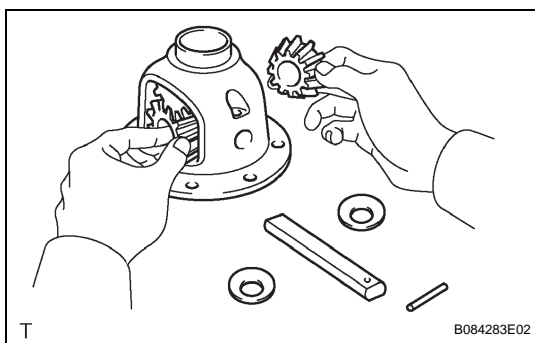

- (b) Install the 2 side gears, 2 pinion gears, 2 side gear thrust washers, 2 pinion thrust washers and pinion shaft into the differential case.

HINT:

Align the holes of the differential case and pinion shaft.

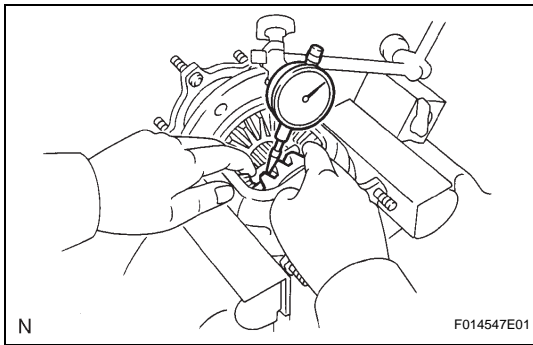

- (c) Measure the side gear backlash.
 (1) Using a dial indicator, measure the side gear backlash while holding one pinion gear toward the differential case.

Backlash:**0.15 mm (0.0059 in.) or less**

If the backlash is not as specified, install 2 side gear thrust washers with different thicknesses.

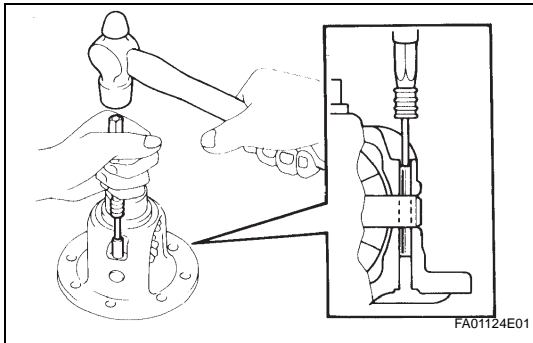

- (d) Using a pin punch and hammer, tap in the straight pin through the differential case and hole of the pinion shaft.
 (e) Stake the differential case.

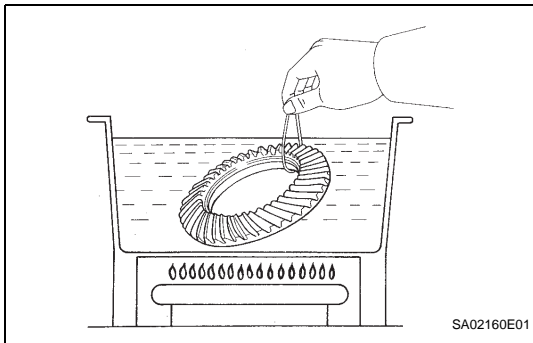
**7. INSTALL DIFFERENTIAL RING GEAR**

- (a) Clean the contact surface of the differential case and ring gear.
 (b) Heat the ring gear in water that is approximately 100°C (212°F).
 (c) Carefully remove the ring gear from the boiling water.
 (d) After the moisture on the ring gear has completely evaporated, quickly install the ring gear onto the differential case.

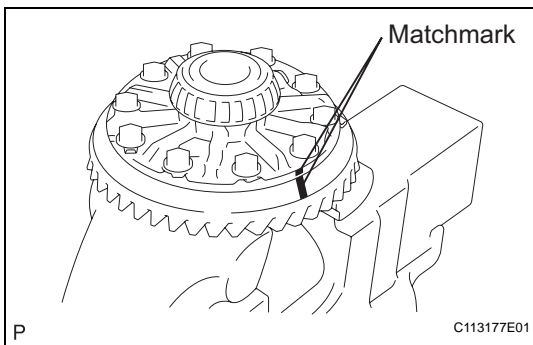

- (e) Align the matchmarks on the ring gear with those of the differential case.
 (f) After the ring gear cools down, apply thread lock adhesive to the 10 set bolts and install them.

Thread lock:

Part No. 08833-00100, THREE BOND 1360k or the equivalent.

Torque: 115 N*m (1,173 kgf*cm, 85 ft.*lbf)

8. INSTALL FRONT DIFFERENTIAL CASE BEARING

- (a) Using SST and a press, press the bearing into the differential case.

SST 09950-60010 (09951-00520, 09951-00610), 09950-70010 (09951-07150)

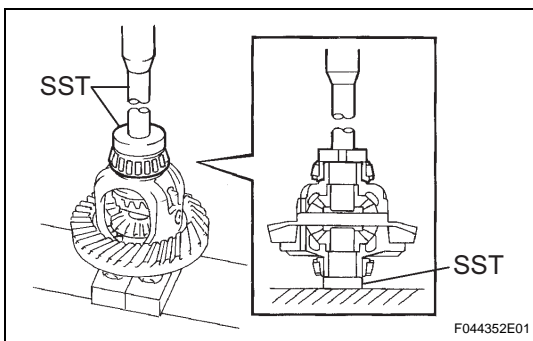

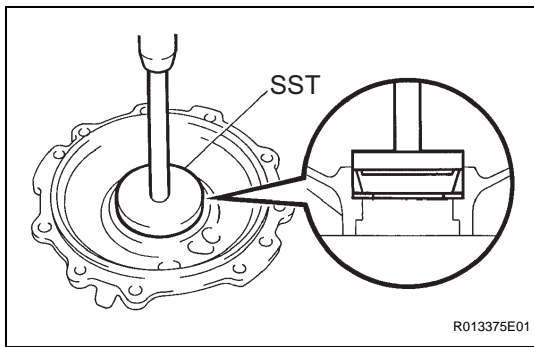

9. INSTALL FRONT DIFFERENTIAL CASE BEARING

HINT:

When replacing the 3 differential case bearings, fit the 2 thinnest new washers onto each bearing. When reusing the bearings, fit the new washers into the same places they were removed from.

- (a) Using SST and a press, press the case bearing (outer race) into the differential case bearing retainer.

SST 09950-60020 (09951-00810), 09950-70010 (09951-07150)

- (b) Using SST and a press, press the case bearing (outer) into the differential carrier.

SST 09950-60020 (09951-00810), 09950-70010 (09951-07150)

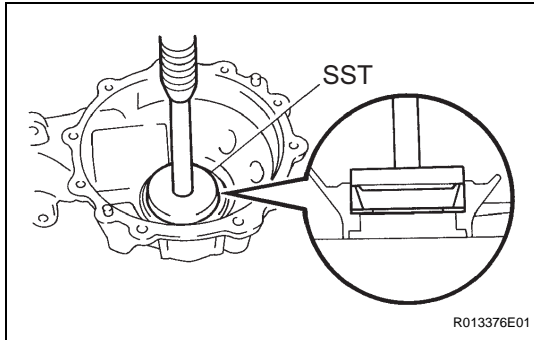

10. INSTALL BEARING OUTER RACE

- (a) Using SST, install the outer race front.

SST 09950-00020 (09951-00890, 09951-00680)

- (b) Using a brass bar and hammer, tap in the oil storage ring.

- (c) Using SST, install the outer race rear.

SST 09950-00020 (09951-00890, 09951-00680)

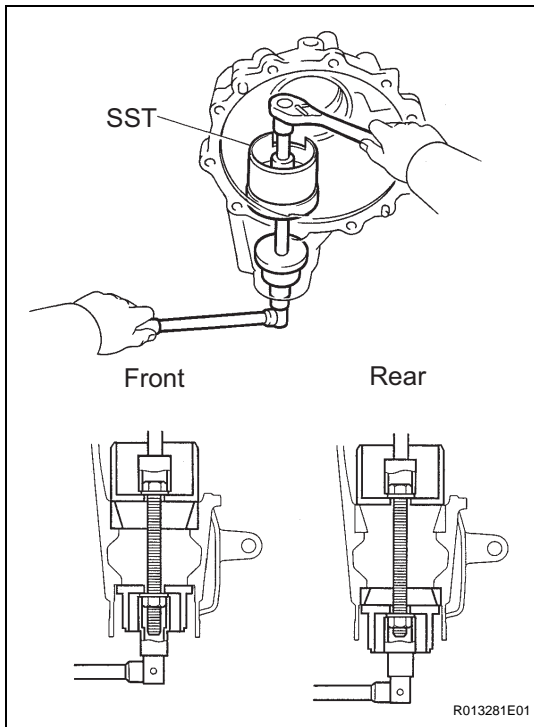

11. INSTALL FRONT DRIVE PINION FRONT TAPERED ROLLER BEARING

- (a) Install the washer onto the drive pinion.

HINT:

First fit a washer that has the same thickness as the removed washer. After checking the tooth contact pattern, replace the washer with one of a different thickness if necessary.

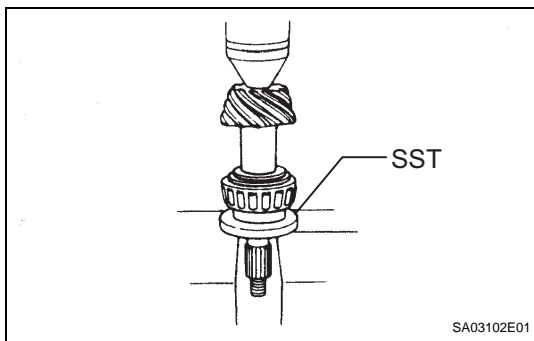

- (b) Using SST and a press, press the front bearing onto the drive pinion.

SST 09506-30012

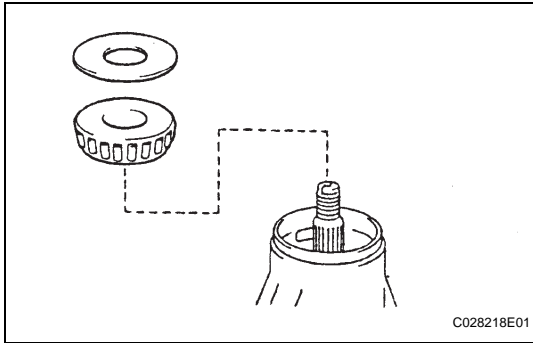

12. ADJUST DIFFERENTIAL DRIVE PINION PRELOAD

- (a) Install the drive pinion and oil slinger.

HINT:

Assemble the spacer and oil seal after adjusting the gear contact pattern.

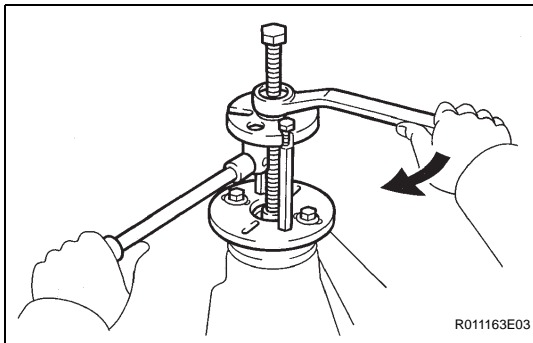

- (b) Using SST, install the companion flange.

SST 09950-30012 (09951-03010, 09953-03010, 09954-03010, 09955-03030, 09956-03020)

NOTICE:

Before using SST (center bolt), apply hypoid gear oil to its threads and tip.

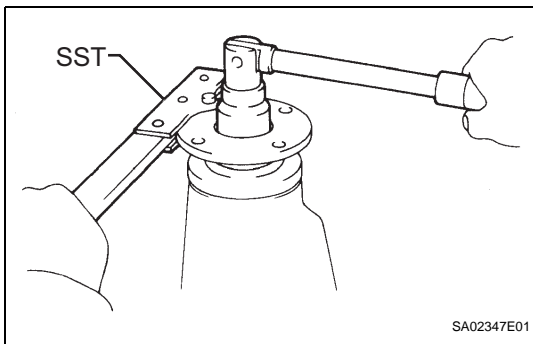

- (c) Adjust the drive pinion preload by tightening the companion flange nut.

- (d) Using SST to hold the flange in place, tighten the nut.

Torque: 370 N*m (3,770 kgf*cm, 273 ft.*lbf) or less

NOTICE:

- As there is no spacer, tighten the nut a little at a time. Be careful not to overtighten it.
- Apply hypoid gear oil to the nut.

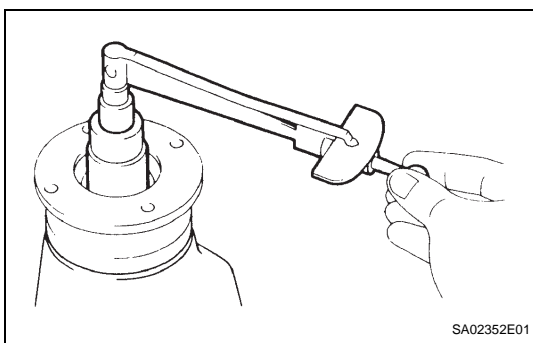

- (e) Using a torque wrench, measure the preload.
Preload (at starting)

Item	Specified Condition
New bearing	0.98 to 1.57 N*m (5 to 8 kgf*cm, 4.3 to 6.9 in.*lbf)
Used bearing	0.49 to 0.78 N*m (5 to 8 kgf*cm, 4.3 to 6.9 in.*lbf)

NOTICE:

For a more accurate measurement, rotate the bearing forward and backward several times before measuring.

13. INSTALL DIFFERENTIAL CASE ASSEMBLY

14. ADJUST DIFFERENTIAL RING GEAR BACKLASH

- (a) Install the side bearing retainer with the 10 bolts.
Torque: 50 N*m (510 kgf*cm, 37 ft.*lbf)

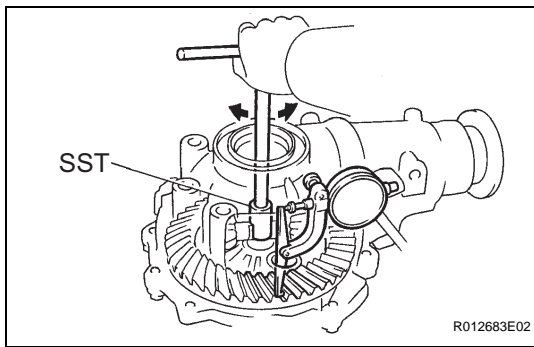

- (b) Using SST and a dial indicator, measure the ring gear backlash.

SST 09564-32011

Backlash:

0.11 to 0.21 mm (0.0043 to 0.0083 in.)

If the backlash is not as specified, adjust it by either increasing or decreasing the number of washers on both sides equally.

HINT:

There should be no clearance between the plate washer and case. Make sure that the ring gear has backlash.

Washer thickness

Thickness mm (in.)	Thickness mm (in.)	Thickness mm (in.)
1.57 to 1.59 (0.0618 to 0.0626)	1.75 to 1.77 (0.0689 to 0.0697)	2.03 to 2.05 (0.0791 to 0.0807)
1.59 to 1.61 (0.0626 to 0.0634)	1.77 to 1.79 (0.0697 to 0.0705)	2.05 to 2.07 (0.0807 to 0.0815)
1.61 to 1.63 (0.0634 to 0.0642)	1.79 to 1.81 (0.0705 to 0.0713)	2.07 to 2.09 (0.0815 to 0.0822)
1.63 to 1.65 (0.0642 to 0.0650)	1.81 to 1.83 (0.0713 to 0.0720)	2.09 to 2.11 (0.0822 to 0.0830)
1.65 to 1.67 (0.0650 to 0.0657)	1.83 to 1.85 (0.0720 to 0.0728)	2.11 to 2.13 (0.0830 to 0.0839)
1.67 to 1.69 (0.0657 to 0.0665)	1.85 to 1.87 (0.0728 to 0.0736)	2.13 to 2.15 (0.0839 to 0.0846)
1.69 to 1.71 (0.0665 to 0.0673)	1.87 to 1.89 (0.0736 to 0.0744)	2.15 to 2.17 (0.0846 to 0.0854)
1.71 to 1.73 (0.0673 to 0.0681)	1.89 to 2.01 (0.0744 to 0.0791)	-
1.73 to 1.75 (0.0681 to 0.0689)	2.01 to 2.03 (0.0791 to 0.0799)	-

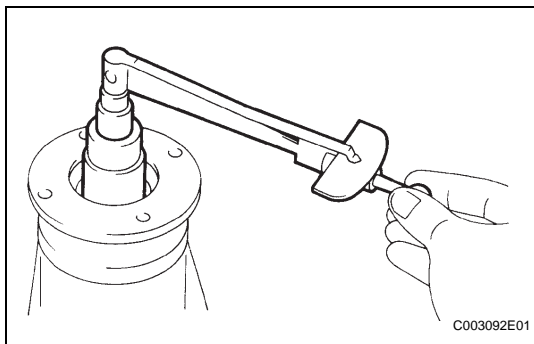

15. INSPECT TOTAL PRELOAD

- (a) Using a torque wrench, measure the preload with the teeth of the drive pinion and ring gear in contact.

HINT:

Bolts without torque specifications are shown in the service data (see page [SS-43](#)).

If necessary, disassemble and inspect the differential.

16. ADJUST TOOTH CONTACT BETWEEN RING GEAR AND DRIVE PINION

- (a) Remove the differential case bearing retainer and differential case.
- (b) Coat 3 or 4 teeth at 3 different positions on the ring gear with prussian blue.
- (c) Install the differential case and differential case bearing retainer.

Torque: 50 N*m (510 kgf*cm, 37 ft.*lbf)

- (d) Hold the companion flange firmly in place and rotate the ring gear in both directions.
- (e) Remove the differential case bearing retainer and differential case.

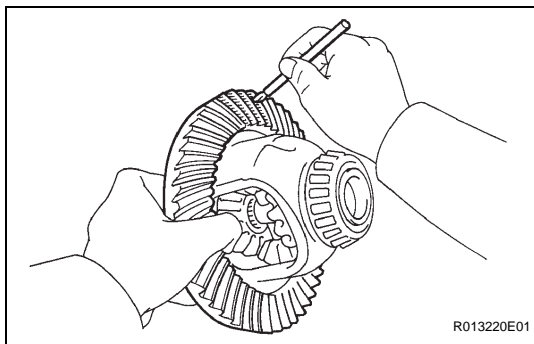

-
- (f) Inspect the tooth contact pattern.

Proper Contact

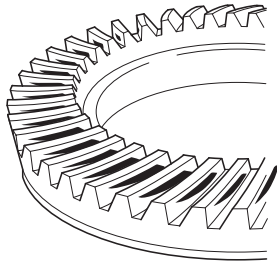

Drive Side

Toe Contact

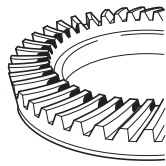

Face Contact

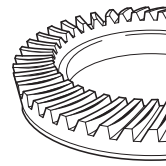

Select an adjusting washer that will shift the drive pinion closer to the ring gear.

Heel Contact

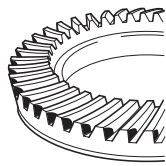

Flank Contact

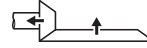
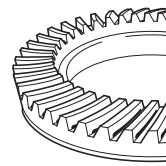

Select an adjusting washer that will shift the drive pinion away from the ring gear.

Coast Side

Heel Contact

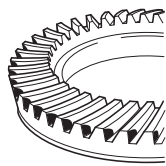

Flank Contact

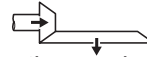
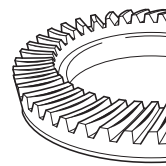

Select an adjusting washer that will shift the drive pinion closer to the ring gear.

Toe Contact

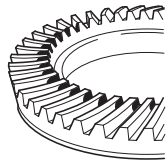

Face Contact

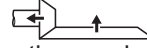
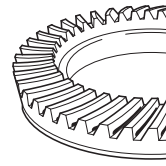

Select an adjusting washer that will shift the drive pinion away from the ring gear.

DF

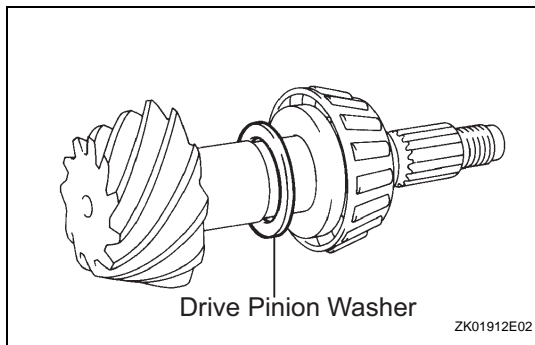

- (g) If the teeth are not contacting properly, use the following chart to select an appropriate washer.

Washer thickness

Thickness mm (in.)	Thickness mm (in.)	Thickness mm (in.)
1.69 to 1.71 (0.0665 to 0.0673)	1.93 to 1.95 (0.0760 to 0.0768)	2.17 to 2.19 (0.0854 to 0.0862)
1.72 to 1.74 (0.0677 to 0.0685)	1.96 to 1.98 (0.0772 to 0.0780)	2.20 to 2.22 (0.0866 to 0.0874)
1.75 to 1.77 (0.0689 to 0.0697)	1.99 to 2.01 (0.0783 to 0.0791)	2.23 to 2.25 (0.0878 to 0.0886)
1.78 to 1.80 (0.0700 to 0.0709)	2.02 to 2.04 (0.0795 to 0.0803)	2.26 to 2.28 (0.0890 to 0.0898)
1.81 to 1.83 (0.0713 to 0.0720)	2.05 to 2.07 (0.0807 to 0.0815)	2.29 to 2.31 (0.0902 to 0.0909)
1.84 to 1.86 (0.0724 to 0.0732)	2.08 to 2.10 (0.0819 to 0.0827)	2.32 to 2.34 (0.0913 to 0.0921)
1.87 to 1.89 (0.0736 to 0.0744)	2.11 to 2.13 (0.0831 to 0.0839)	-
1.90 to 1.92 (0.0748 to 0.0756)	2.14 to 2.16 (0.0843 to 0.0850)	-

17. REMOVE FRONT DRIVE PINION COMPANION FLANGE NUT (See page [DF-23](#))
18. REMOVE FRONT DRIVE PINION COMPANION FLANGE SUB-ASSEMBLY (See page [DF-24](#))
19. REMOVE FRONT DIFFERENTIAL DRIVE PINION OIL SLINGER
20. REMOVE FRONT DRIVE PINION REAR TAPERED ROLLER BEARING (See page [DF-24](#))
21. INSTALL FRONT DIFFERENTIAL DRIVE PINION BEARING SPACER
 - (a) Install a new bearing spacer onto the drive pinion.

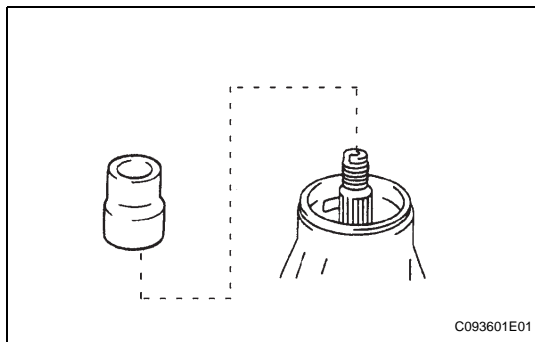

C093601E01

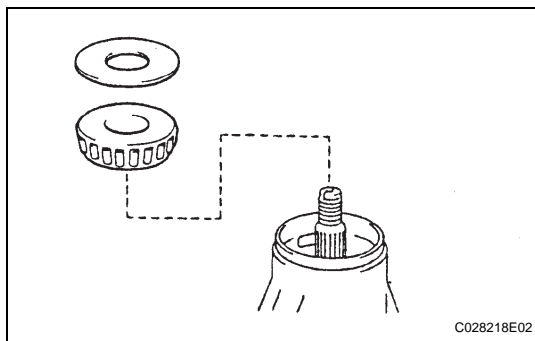

C028218E02

22. INSTALL FRONT DRIVE PINION REAR TAPERED ROLLER BEARING
23. INSTALL FRONT DIFFERENTIAL DRIVE PINION OIL SLINGER

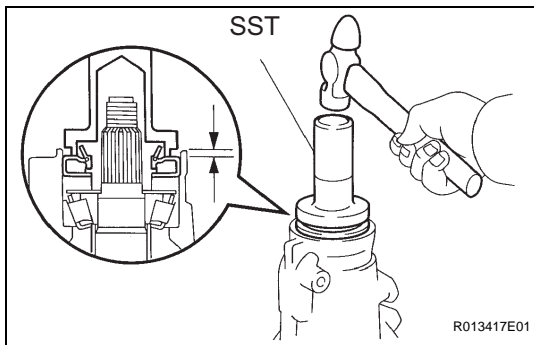
**24. INSTALL FRONT DIFFERENTIAL CARRIER OIL SEAL**

- (a) Apply MP grease to the lip of a new oil seal.
- (b) Using SST and a hammer, tap in the oil seal.

SST 09554-22010

Oil seal depth:

3.9 to 48 mm (0.1536 to 0.189 in.)

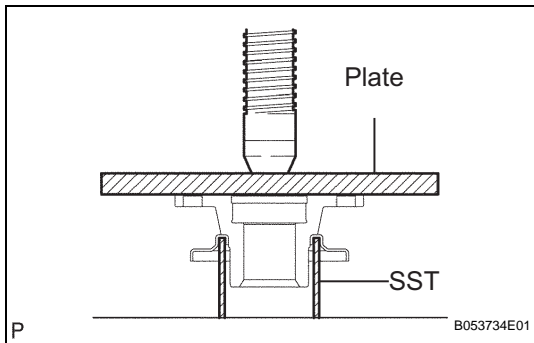
**25. INSTALL FRONT DIFFERENTIAL DUST DEFLECTOR**

- (a) Using a steel plate and a press, press in a new dust deflector.

NOTICE:

Do not damage the dust deflector.

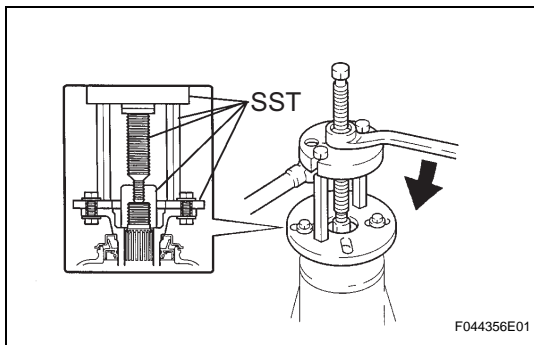
**26. INSTALL FRONT DRIVE PINION COMPANION FLANGE SUB-ASSEMBLY**

- (a) Place the companion flange on the drive pinion.
- (b) Coat the threads of a new nut with hypoid gear oil.
- (c) Using SST, install the companion flange.

SST 09950-30012 (09951-03010, 09953-03010, 09954-03010, 09955-03030, 09956-03020)

NOTICE:

Before using SST (center bolt), apply hypoid gear oil to its threads and tip.

- (d) Using SST to hold the companion flange in place, tighten the nut to the correct torque.

SST 09330-00021 (09330-00030)

Torque: 370 N*m (3,770 kgf*cm, 273 ft.*lbf) or less

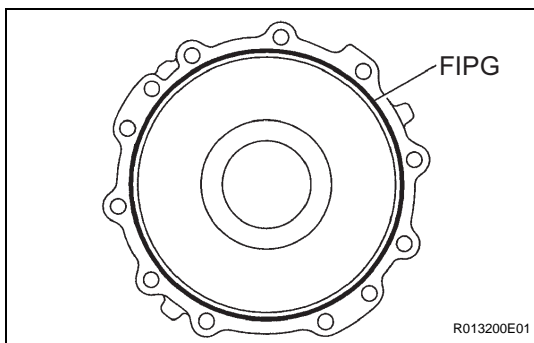
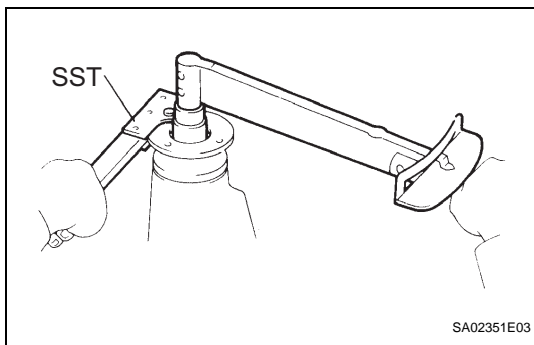
**27. INSTALL DIFFERENTIAL SIDE BEARING RETAINER**

- (a) Remove any old FIPG material from the side bearing retainer.

NOTICE:

Do not drop oil on the contact surfaces of the differential carrier and side bearing retainer.

- (b) Clean residual FIPG material from the contact surface using gasoline or alcohol.

- (c) Apply FIPG to the side bearing retainer, as shown.

FIPG:

Part No. 08826-00090, THREE BOND 1281 or the equivalent

HINT:

Install the side bearing retainer within 10 minutes of applying FIPG.

- (d) Install the side bearing retainer with the 10 bolts.

Torque: 50 N*m (510 kgf*cm, 37 ft.*lbf)

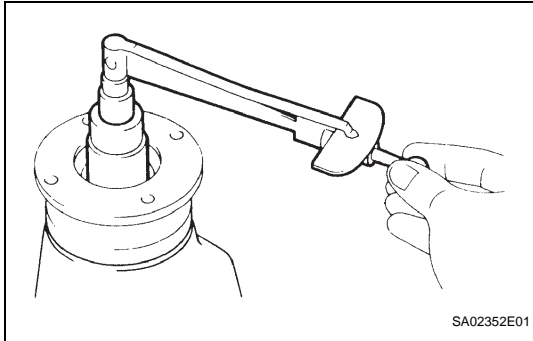
**28. INSPECT DRIVE PINION PRELOAD**

- (a) Using a torque wrench, measure the preload of the backlash between the drive pinion and ring gear.

Preload (at starting)

Item	Specified Condition
New bearing	0.98 to 1.57 N*m (10 to 16 kgf*cm, 8.7 to 14 in.*lbf)
Used bearing	0.49 to 0.78 N*m (5 to 8 kgf*cm, 4.3 to 6.9 in.*lbf)

If the preload is greater than the maximum, replace the bearing spacer.

If the preload is less than the minimum, retighten the nut with 13 N*m (130 kgf*cm, 9 ft.*lbf) of torque at a time until the specified preload is reached.

Torque: 370 N*m (3,770 kgf*cm, 273 ft.*lbf) or less

If the maximum torque is exceeded while retightening the nut, replace the bearing spacer and repeat the preload adjusting procedure.

HINT:

Do not loosen the pinion nut to reduce the preload.

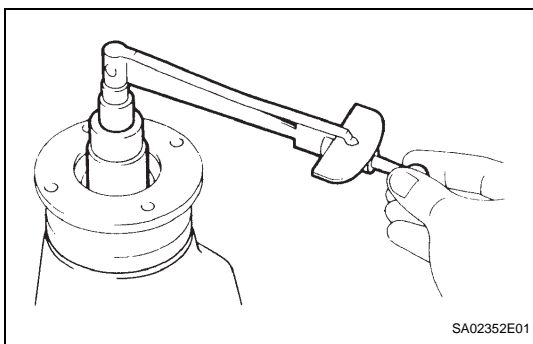
**29. INSPECT TOTAL PRELOAD**

- (a) Using a torque wrench, measure the preload with the teeth of the drive pinion and ring gear in contact.

Torque: Total preload (at starting)

0.22 to 0.88 N*m (6 to 9 kgf*cm, 1.9 to 8.8 in.*lbf) drive pinion preload plus

HINT:

Bolts without torque specifications are shown in the service data (see page [SS-43](#)).

If necessary, disassemble and inspect the differential.

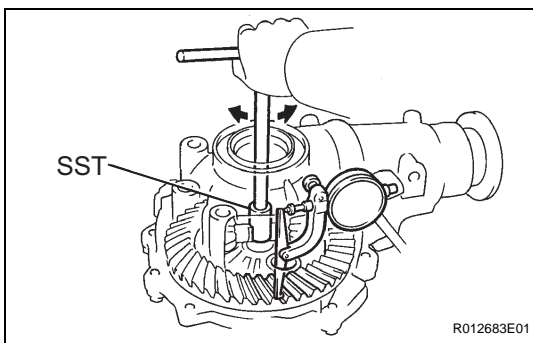
**30. INSPECT DIFFERENTIAL RING GEAR BACKLASH**

- (a) Using SST and a dial indicator, measure the ring gear backlash.

SST 09564-32011**Backlash:**

0.11 to 0.21 mm (0.0043 to 0.0083 in.)

If the backlash is not within the specification, adjust the side bearing preload.

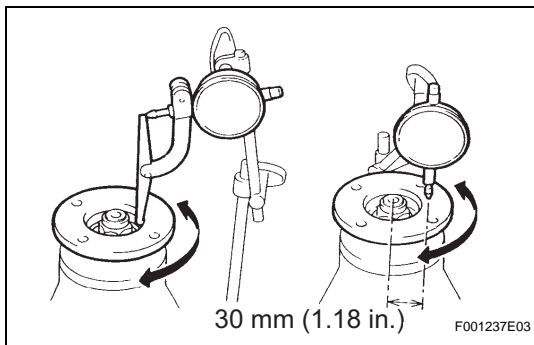

31. INSPECT FRONT DRIVE PINION COMPANION FLANGE SUB-ASSEMBLY

- (a) Using a dial indicator, measure the runout of the companion flange vertically and laterally.

Maximum runout

Runout	Maximum
Vertical runout	0.10 mm (0.0039 in.)
Lateral runout	0.10 mm (0.0039 in.)

If the runout is greater than the maximum, replace the companion flange.

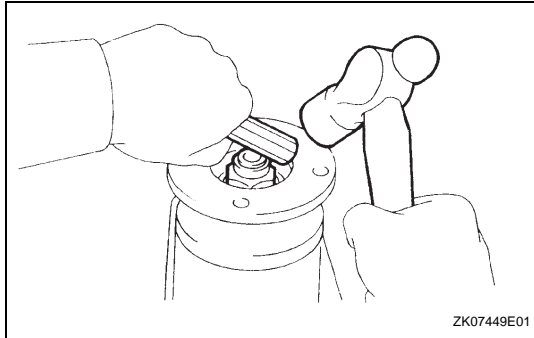

32. STAKE DRIVE PINION COMPANION FLANGE NUT

- (a) Using a chisel and hammer, stake the drive pinion nut.

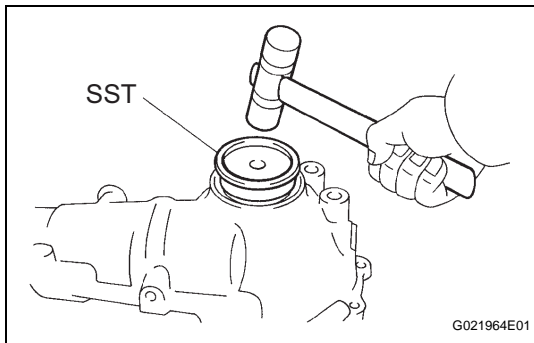

33. INSTALL DIFFERENTIAL SIDE GEAR SHAFT OIL SEAL

- (a) Coat the lip of a new oil seal with MP grease.
 (b) Using SST and a plastic-faced hammer, tap in the oil seal until its surface is flush with the differential carrier end.

SST 09608-32010

Oil seal depth:

-0.45 to 0.45 mm (-0.018 to 0.018 in.)

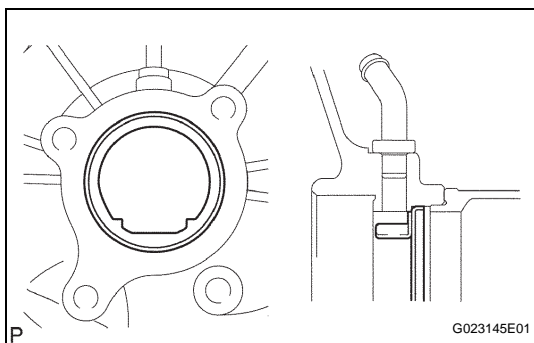

34. INSTALL FRONT DIFFERENTIAL SIDE BEARING RETAINER DEFLECTOR

- (a) Using a brass bar and hammer, tap in the side bearing retainer deflector.

NOTICE:

Install the side bearing retainer deflector in the correct direction.

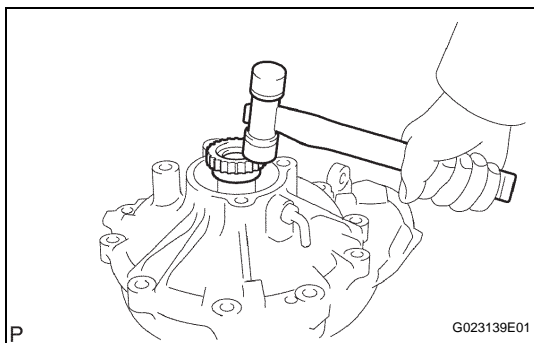

35. INSTALL DIFFERENTIAL SIDE GEAR INTER SHAFT SUB-ASSEMBLY

- (a) Install a new snap ring onto the side gear inter shaft.
 (b) Using a plastic-faced hammer, tap the side gear inter shaft into the differential case.
 (c) Check that there is 2 to 3 mm (0.08 to 0.12 in.) of axial play.
 (d) Check that the side gear inter shaft cannot be completely pulled out by hand.

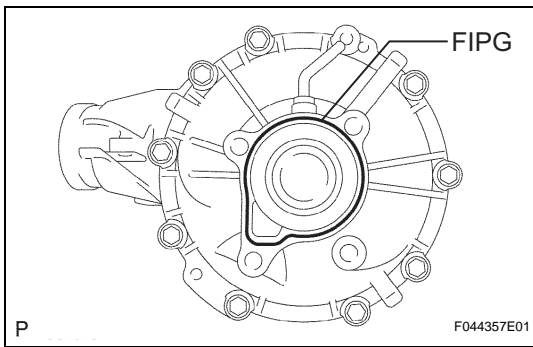
**36. INSTALL FRONT DIFFERENTIAL TUBE ASSEMBLY**

- (a) Remove any old FIPG material from the contact surfaces of the differential and clutch case.

NOTICE:

Do not drop oil on the contact surfaces of the differential and clutch case.

- (b) Clean residual FIPG material from the contact surface using gasoline or alcohol.
 (c) Apply FIPG to the differential as shown.

FIPG:

Part No. 08826-00090, THREE BOND 1281 or the equivalent

HINT:

Install the differential tube within 10 minutes of applying FIPG.

- (d) Install the differential tube onto the differential.
 (e) Clean the threads of the 4 bolts and retainer bolt holes with toluene or trichloroethylene.
 (f) Apply adhesive to 2 or 3 threads of each bolt end.

Adhesive:

Part No. 08833-00070, THREE BOND 1281 or the equivalent

- (g) Install the 4 bolts.

Torque: 110 N*m (1,120 kgf*cm, 81 ft.*lbf)

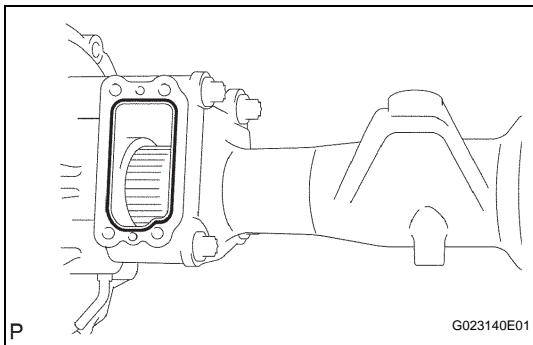
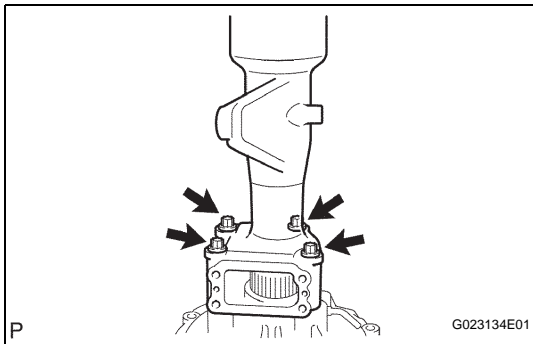
**37. INSTALL DIFFERENTIAL VACUUM ACTUATOR ASSEMBLY**

- (a) Remove any FIPG material from the contact surface of the differential and clutch case. Also, do not drop oil on the contact surfaces.
 (b) Clean residual FIPG material from the contact surfaces using gasoline or alcohol.
 (c) Apply FIPG to the differential tube as shown.

FIPG:

Part No. 08826-00090, THREE BOND 1281 or the equivalent

HINT:

Install the actuator within 10 minutes of applying FIPG.

- (d) Clean the threads of the 4 bolts and retainer bolt holes with toluene or trichloroethylene.
 (e) Install the actuator onto the differential tube.
 (f) Apply adhesive to 2 or 3 threads of each bolt end.

Adhesive:

Part No. 08833-00070, THREE BOND 1281 or the equivalent

- (g) Install the 4 bolts.

Torque: 21 N*m (210 kgf*cm, 15 ft.*lbf)

